



CDVI

Security to Access

Product Catalogue

2020

KRYPTO

HIGH SECURITY SOLUTION

Say "NO" to card cloning with ATRIUM's unique KRYPTO high security solution. Eliminate complex and arduous programming using the ATRIUM A22K controller, CDVI Mifare DesFire EV2 credentials and K1 readers. System-wide AES encryption stops card cloning and provides end-to-end security. Whether you remote in from the internet or connect on your network you can be sure KRYPTO has you covered.



A22K

ENCRYPTED 2-DOOR / 4-READER IP CONTROLLER

(SEAMLESSLY INTEGRATES WITH EXISTING ATRIUM SYSTEMS)



USB Backup Port
(Disaster recovery, user photos & video clips)

AES 256 Encryption
Military grade Ethernet Port

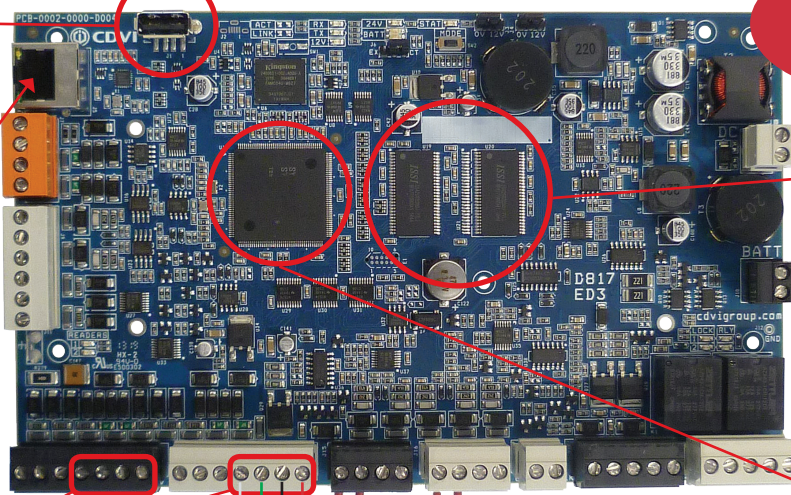

Instant High Security Out of the Box

Increased Memory
Provides space for future expansion and integration



New Microprocessor

- HTTPS enabled
- IPV6 ready

CDVI Encryption

- RS-485 encrypted reader BUS using CDVI KRYPTO reader
- Supports 2 readers per port (Entry/Exit)
- OSDP-2 Compatible

AES 128 Encryption
(using Mifare DESFire EV2 card)



K1

KRYPTO High Security Card Reader



- Compatible with ATRIUM A22K controller
- FULLY secure RS-485 connection (4 wires)
- Reads 13.56 MHz Mifare® Classic and DESFire EV1/EV2
- OSDP-2 compatible
- NFC compatible (mobile credential ready)
- Up to 2" (5 cm) read range
- Power requirements: 12 VDC

System Overview



Supports any combination of fifty A22K, A22KEC and/or ADH10 controllers for a maximum of 500 doors

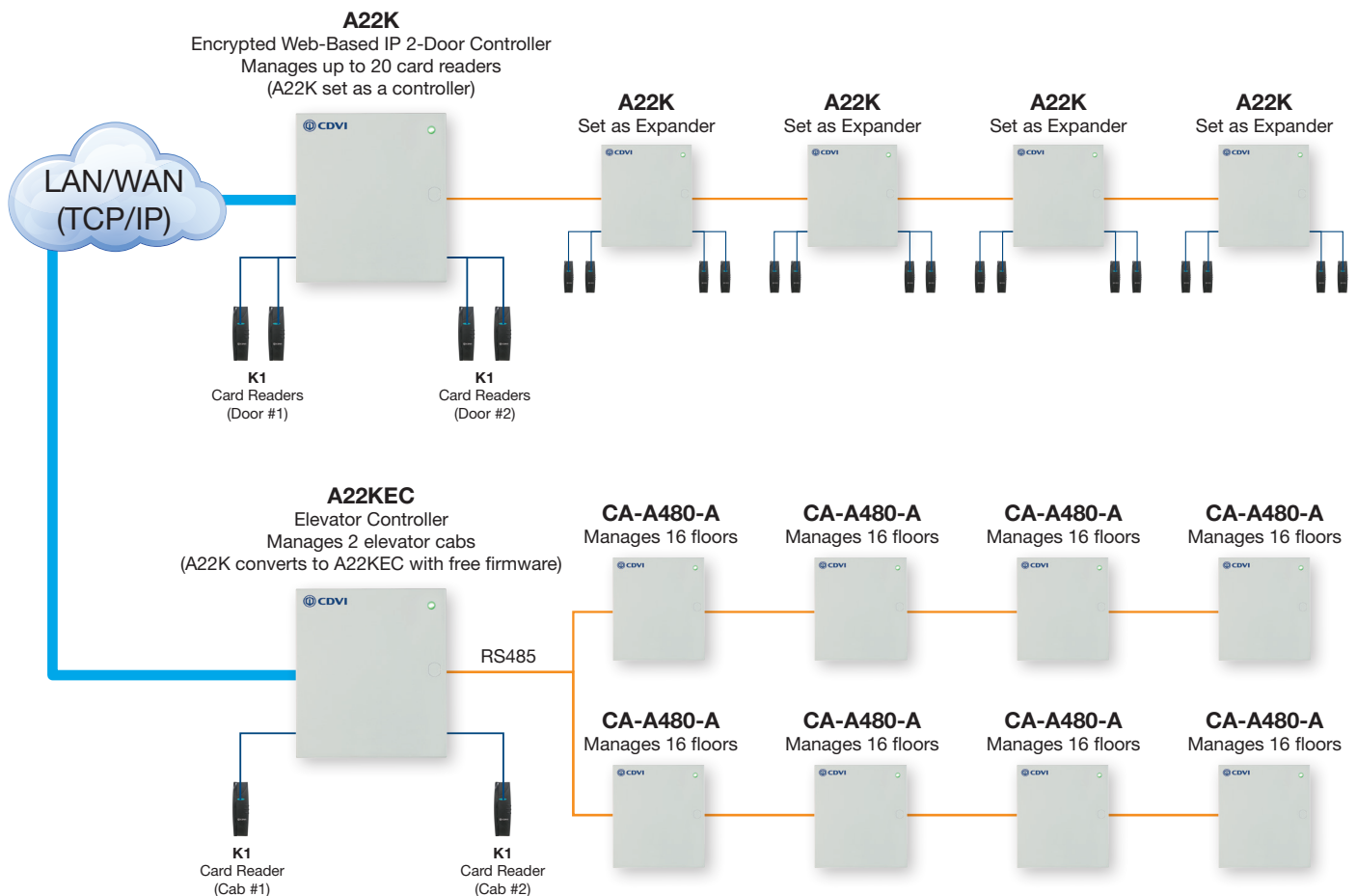

A22K

Encrypted 2-Door / 4-Reader Web-Based IP Controller



The A22K is ATRIUM's encrypted web-based (https) door controller. Use your smartphone, tablet or any web-enabled device to easily manage the system over a secure connection in the office, at home or on the road! ATRIUM's unique and effortless card enrollment mode minimizes system start up and simplifies your life. A factory-installed power supply (A22K) or POE+ Splitter (A22KPOE) makes the A22K an industry leader in cost-efficiency and simplicity. Just plug it into an AC wall outlet to power the unit, readers and door locks.

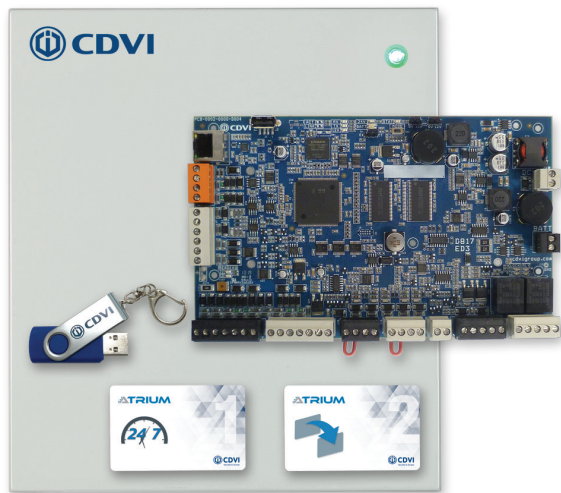

- Controls 2 doors and 4 readers (Entry/Exit per reader port)
- Pre-assembled universal plug-in power supply (120V/240V)
- Also available with pre-assembled PoE+ splitter: A22KPOE
- FREE Management Software
- Converts the A22K to an elevator controller (A22KEC) by changing is firmware for free (The A22KEC can manage up to 256 floors)
- On-board Ethernet Port with AES 256-bit encryption
- On-board RS485 communication bus, 4000 ft (1220 m)
- Embedded secure https Web Server
- Auto-detect expansion modules
- 10,000 users & cards
- 25,000 Event Buffer
- 100 holidays
- 1,000 Access Levels
- 250 Schedules each supporting up to 100 time periods
- 256 floor levels
- Lock outputs: 2 (750 mA @ 12 VDC/each)
- Relay Outputs: 2 Form C relays (Dry Contact) 5 A at 250 VAC, 7 A @ 125 VAC, 7A @ 30 VDC
- 6 multi-purpose inputs (12 using zone doubling)
- Entirely fuseless system
- Maintenance-friendly snap on terminal connectors

CA-A480-A

Elevator Controller

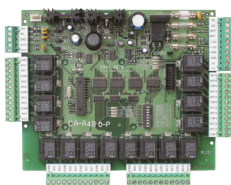

- Up to eight CA-A480-A controllers per A22KEC elevator controller
- RS-485 connectivity to the A22KEC up to 4000 ft (1220 m)
- 16 Form C floor control relays (15A/28 VDC, N.C./N.O.)
- 1 Fire control input + 1 Tamper input
- Destination reporting (requires CA-A482-P)
- Backup battery with selectable battery charge current
- On-board 12 VDC power supply
- Fully supervised (tamper, low battery and AC failure) with LED display

CA-A482-P

Destination Reporting Module

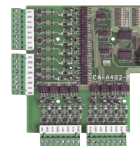

- Connects directly onto the CA-A480-A elevator controller
- User must present a valid card to select a floor button.
- 16 floor-selection inputs and LED indicators
- Records Valid and Invalid floor selections
- Power input: 5 VDC
- Current consumption: 28 mA (typical), 108 mA (max)
- DC input activation: 15 VDC (minimum), 165 VDC (max)

ADH10

Schlage® Door Handle Controller



The ATRIUM ADH10 controller can control up to ten AD300, AD400 and NDE SCHLAGE door handles. ATRIUM ver. 3.2 (or higher) multi-account software supports up to 500 door handles per account (site). This is done by using ten ADH10 controllers connected to an IP network. Effortless auto-detect technology identifies the SCHLAGE door handle on the communication bus. A pre-assembled universal power supply is included with every ADH10 making this unit an industry leader in efficiency and simplicity.

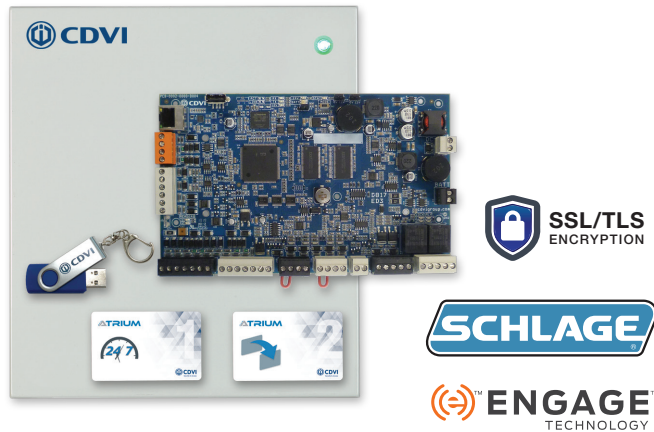

- Controls 10 Schlage AD 300/400 or NDE series door handles
- On-board Ethernet Port with AES 256-bit encryption
- Embedded secure https Web server
- On-board RS485 communication bus, 4000 ft (1220 m)
- Pre-assembled universal plug-in power supply (120V / 240V)
- Auto-detect technology
- 10,000 users
- 10,000 cards
- 25,000 Event Buffer
- 100 holidays
- 1,000 Access Levels
- 250 Schedules each supporting up to 100 time periods
- Comprehensive LED status indicators

AIOM

10-Input/10-Output Module



- 10 Inputs (20 using zone doubling technology)
- 10 Outputs
- Auto-detect technology (No jumpers or DIP switches)
- 4000 ft (1220 m) 4 conductor RS485 expansion bus
- Comprehensive LED status indicators

AFPLAN

ATRIUM Floor Plan Manager License



- View door status on a floor plan in real time from any web browser (MAC or PC).
- Activate all door options in real time (locked, unlocked, access granted, etc.)
- Easy to configure (click & drag)
- Supports .jpg or .png file (1Mb max.)
- One Floor Plan Manager per site

GWE

ENGAGE™ Gateway



- Capable of managing up to 10 ENGAGE™ enabled devices for a wide range of applications
- Secure AES-256 bit encrypted 2.4 GHz Bluetooth 4.0 communication between Gateway and ENGAGE™ devices

PIM400-485

Schlage Panel Interface Module



- 900 MHz Spread Spectrum RF technology for long range, reliable communication
- Automatic linking to remote wireless access points with 10 channel frequencies to select from enables easy commissioning
- AES-128 bit Encrypted Spread Spectrum transmissions
- AD-Series compatible

A22K1

ONE A22K CONTROLLER & TWO READERS KIT

KRYPTO
HIGH SECURITY SOLUTION



*Embedded
Web Server*

*Pre-assembled
Universal Power Supply*
(Optional PoE+ available)

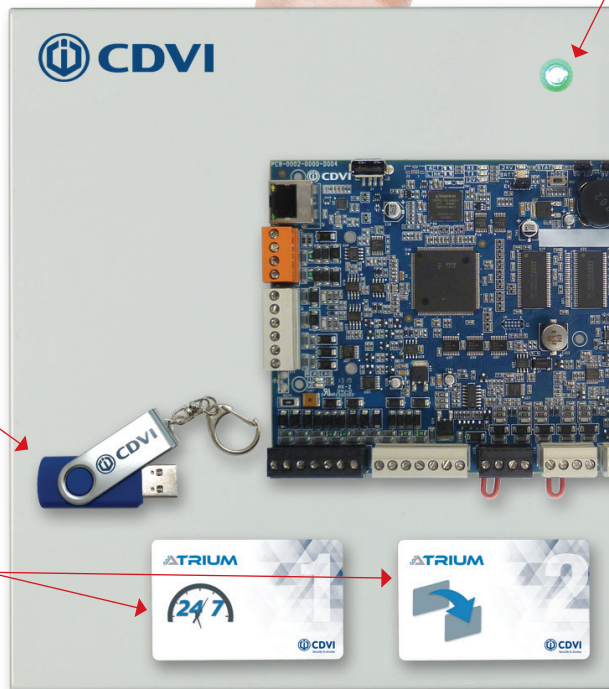

**FREE
Software**

**Quick & Easy
Card Enrollment**
(No computer required)



**High Security
Card Readers**
(2 x Krypto K1)

**Mifare
DESFire EV2 Tags**
(25 x TAGEV2)



A22K1DS

ONE A22K CONTROLLER, TWO READERS & TWO DOOR STRIKES KIT

KRYPTO
HIGH SECURITY SOLUTION



*Embedded
Web Server*

*Pre-assembled
Universal Power Supply*
(Optional PoE+ available)

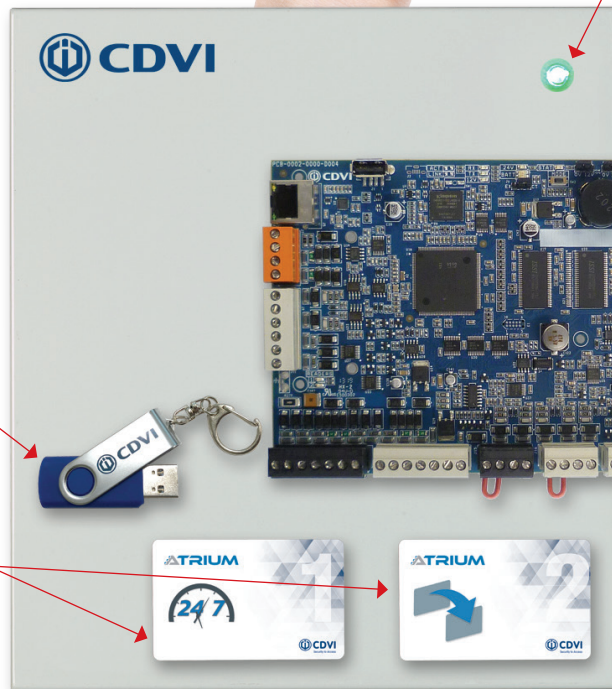

**FREE
Software**

**Quick & Easy
Card Enrollment**
(No computer required)

**High Security
Card Readers**
(2 x Krypto K1)



**Mifare
DESFire EV2 Tags**
(25 x TAGEV2)



**Two Heavy Duty
Stainless Steel
Door Strikes Kit**

(2 x 2400KIT)

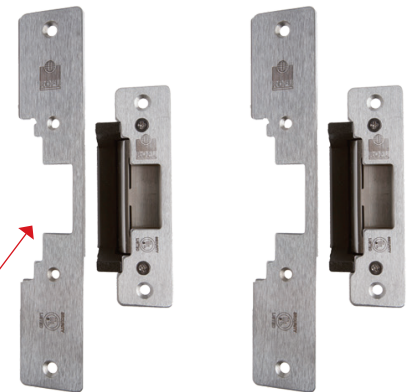



Software Editions



CENTAUR V6.0 and higher

	LITE*	STANDARD	PROFESSIONAL	ENTERPRISE	GLOBAL
Sites	1	64	64	64	100
Serial Ports	1	1	1	4	4
Dial Up connection	✓	✓	✓	✓	✓
TCP/IP connection	✓	✓	✓	✓	✓
Cards (per site)	512	2,048	8,196	16,384	16,384
Controllers (per site)	16	32	64	256	256
Doors (per site)	16	128	512	2048	2048
Elevator Control	-	✓	✓	✓	✓
Elevator Cabs (per site)	-	64	128	512	512
Floors per cab	-	64	64	64	64
Floor groups (per site)	-	128	128	128	128
Include built-in Integration	-	✓	✓	✓	✓
GLOBAL COMMUNICATION	-	-	-	-	✓
Global User Groups	-	-	-	-	2048
Global Access Levels	-	-	-	-	256
Global Schedules	-	-	-	-	256
Additional Workstation License	-	-	1	1	1

* FREE from our web site, www.cdvi.ca (Security dongle **NOT** required)

CENTAUR GLOBAL - Multi-Site Management Software

Multi-site database management and simultaneous multi-site communication are powerful additions featured only in CENTAUR's Global Edition software. Users/Cards, Schedules, Access Levels and Holidays are sent to each site automatically, eliminating tedious and repetitive database management. React to remote site alarm conditions instantly at one central or multiple distinct consoles for the utmost in crisis management situations.

Centaur®

INTEGRATED ACCESS CONTROL

POWERFUL INTEGRATION AND ADVANCED MONITORING TOOLS YOURS FOR FREE

DVR/NVR/VMS Integration

View live or recorded video within Centaur. Every Centaur event can be associated to a specific camera. Door forced, door ajar, access granted/denied, lost/stolen cards, temperature sensor alarms and much more.

Centaur displays up to 1 minute prior and 1 minute after of video and/or sends a record command to the video management software. At any time, a system operator can instantly save a picture during playback or live viewing.



SAP Integration

Automatically add, delete or modify Centaur's card database from an external SAP application. Import card data from external human resource databases every 15 minutes. Convenience and functionality are yours for free.



Pro-Report:

On demand, scheduled or customized reports

FrontView: Live interactive floor plans

FrontGuard: Display real-time visual authentication

FrontDesk: Add, delete, modify & print cards, including Photo-ID

Locator:

Monitor real-time location of each card holder

WavePlayer: Play a sound on any system event

Visitor Management

Keeps a complete record of all visitor activities and keeps each visitor's information for subsequent visits. Centaur's Visitor Module will securely validate the comings and goings of all visitors.



Guard Tour Integration

Live interactive guard tour allows check point validation using card readers, input points (motion sensors, key switches, or push buttons) or data collectors (PulseStar Data Collection System by Videx). Includes live alarms for time violations and intuitive exception reports.



Parking Management

Centaur Parking Management provides a parking activity monitor. Quickly view how many parking spaces are being used and by which user, as well as how many parking spaces are available. Manually allocate or free parking spaces. Activate a "PARKING FULL" sign when parking capacity is reached.



Asset Management

Why buy something that you already have? Keep track of your assets and save time and money. Quickly find who is in possession of your assets.



Centaur®

INTEGRATED ACCESS CONTROL

CT-V900-A

2-Door Controller



The CT-V900-A is at the heart of every Centaur access control system. The Centaur Server, hardware expander modules, multi-purpose inputs, card readers, keypads and outputs are connected directly to the CT-V900-A. Multi-controller systems are joined together via the RS-485 communication bus. Distributed database architecture allows each controller to make split-second decisions without needing the server computer. Lightning-quick, robust and remarkable stability make the CT-V900-A the professional's choice.

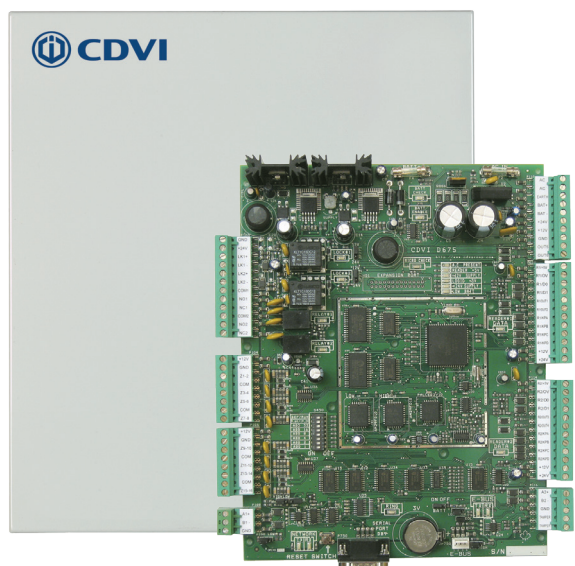

- Controls 2 doors/readers (up to 8 using three CA-A470-A 2-door expander modules)
- Pre-assembled universal plug-in power supply (120V/240V)
- Also available with pre-assembled PoE+ splitter: **CT-V900-APOE**
- On-board Ethernet Port with AES 256-bit encryption
- Fully distributed database architecture (access decisions made locally)
- On-board RS485 communication bus, 4000 ft (1220 m)
- Auto-detect hardware modules (No DIP switch)
- 256 Schedules
- 256 Access Levels
- 2048 Event Buffer
- Lock outputs: 2 (750 mA @ 12 VDC/each)
- Relay Outputs: 2 Form C relays (Dry Contact) 5 A at 250 VAC, 7 A @ 125 VAC, 7 A @ 30 VDC
- 6 multi-purpose inputs (12 using zone doubling)
- Support IPV6
- Entirely fuseless system
- Ultra fast firmware updating
- Maintenance-friendly snap on terminal connectors
- Comprehensive LED status indicators

CA-A470-A

2-Door Expander Module

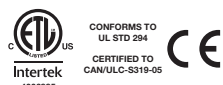
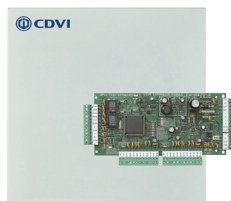

- Control 2 readers and/or keypads
- Up to 3 CA-A470-A modules per CT-V900-A
- 2 form C relays 15A/28 VDC, N.C./N.O. lock outputs
- 4 Inputs (door contacts and REX devices)
- 6 open collector, 50 mA Sink, reader outputs
- E-Bus connectivity to the CT-V900-A up to 4000 ft (1220 m)
- Supports most common Wiegand formats, Magnetic Stripe Track II ABA, BCD keypad formats
- Comprehensive LED status indicators

RSIP

RS-232 to TCP/IP Converter



- Interface: 10Base-T /100Base-T (Auto-sensing)
- Speed: 10/100 Mbps
- Connector: RJ45
- Protocols: UDP, TCP, ARP, Telnet, ICMP, SNMP, DHCP, BOOTP, TFTP, Auto IP, HTTP, Telnet Com Port Control
- Baud Rate: 300 bps to 921.6 Kbps
- Characters: 7 or 8 data bits
- Temperature Range: -40° to 85°C (-40° to 185° F)

CA-A360-USB CAB

RS-232 and/or USB to RS-485 Converter



- Converts RS-232 or USB to RS-485 protocol
- Work with UTP cable (Cat 5)
- Power Requirements: 12 VDC or via USB power
- Current consumption: 100 mA
- Operating temp: -10°C to 55°C (14°F to 131°F)

Centaur®

INTEGRATED ACCESS CONTROL

CA-A480-A

Elevator Controller

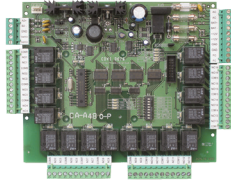

- 16 Form C floor control relays (15 A/28 VDC, N.C./N.O.)
- 1 Fire control input + 1 Tamper input
- Control up to 64 floors and 2 elevator cabs
- Destination reporting (requires CA-A482-P)
- E-Bus connectivity to the CT-V900-A up to 4000 ft (1220 m)
- Backup battery with selectable battery charge current
- On-board 12 VDC power supply
- Fully supervised (tamper, low battery and AC failure) with LED display
- Up to 8 CA-A480-A controller per CT-V900-A controller



CA-A482-P

Destination Reporting Module

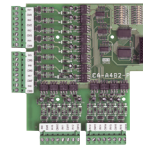

- Connects directly onto the CA-A480-A elevator controller
- User must present a valid card to select a floor button.
- 16 floor-selection inputs and LED indicators
- Records Valid and Invalid floor selections
- Power input: 5 VDC
- Current consumption: 28 mA (typical), 108 mA (max)
- DC input activation: 15 VDC (minimum), 165 VDC (max)

CA-A370-P

RS-485 Network Hub

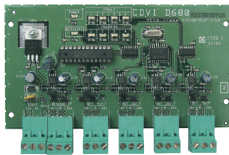

- Provides a higher network isolation from noise
- Create 4 independent RS-485 networks from 1 RS-485 network
- Connect controllers or expander modules up to 4000 ft (1220 m) from the hub
- Power Requirements: 12 VDC
- Current consumption: 190 mA
- Operating temp: -10°C to 55°C (14°F to 131°F)

CA-A110-P

Lock Control Module

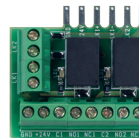

- Simplifies the installation of dual-locking doors (2 maglocks or combination of a maglock and a door strike)
- Lock outputs: 2 form C relays rated at 5 A/12 VDC, N.C./N.O.
- 2 relay status LEDs
- Connects directly to the CT-V900-A lock output terminals
- Current consumption: 100 mA



CA-A460-P

Relay Expander Module

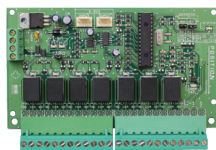

- Adds 7 form C relay outputs (5A/28VDC) to the CT-V900-A controller
- Up to 2 CA-A460-P modules per CT-V900-A controller
- E-Bus connectivity to the CT-V900-A up to 4000 ft (1220 m)
- Power Requirements: 12 VDC
- Current consumption: 50 mA (typical), 400 mA (maximum)

CK-TRAK-L

Tracker LCD Display



- Adjustable backlight and contrast
- Display unit for time and attendance
- 32-character LCD display (2 lines – 16 characters each)
- Can be used with Anti-passback applications to display user locations
- Power Requirements: 9 to 16VDC
- E-Bus connectivity to the CT-V900-A up to 4000 ft (1220 m)
- LCD: Super Twisted Nematic display (STN) Wide viewing angle
- Up to 8 CK-TRAK-L modules per CT-V900-A controller

System Overview

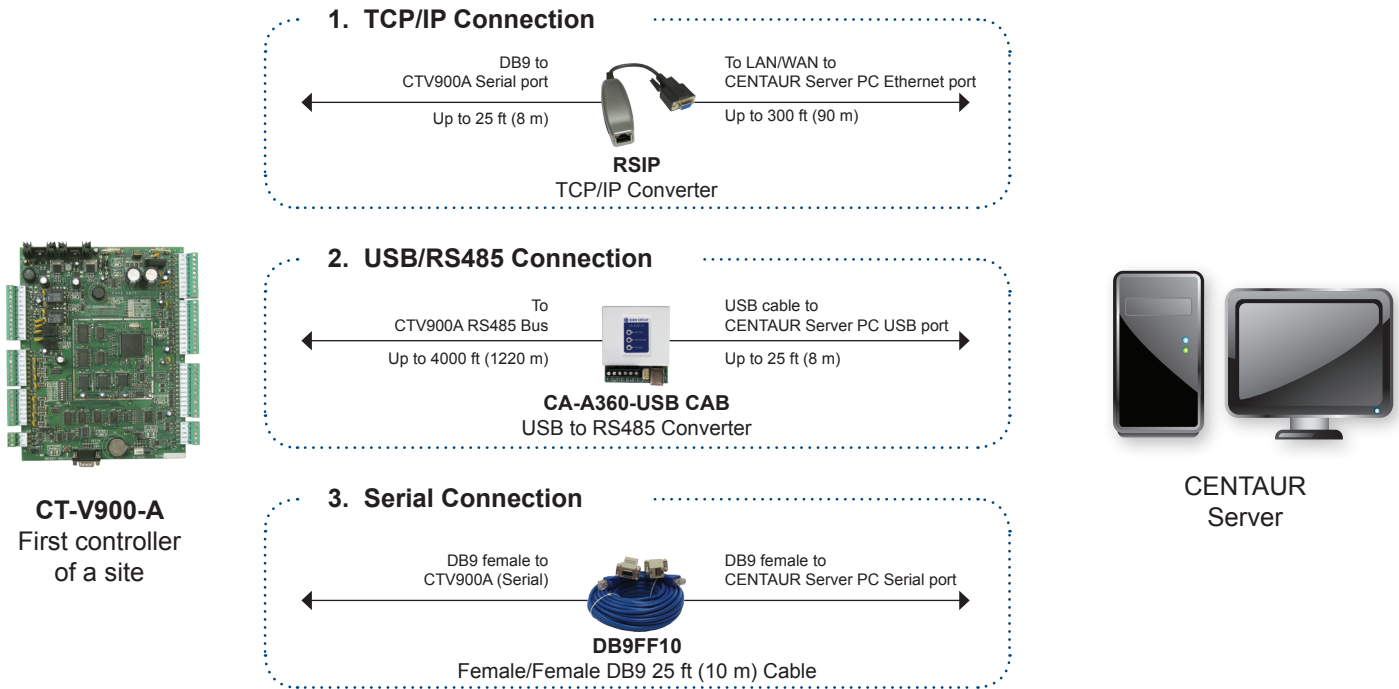

E-bus Network Module Capacity

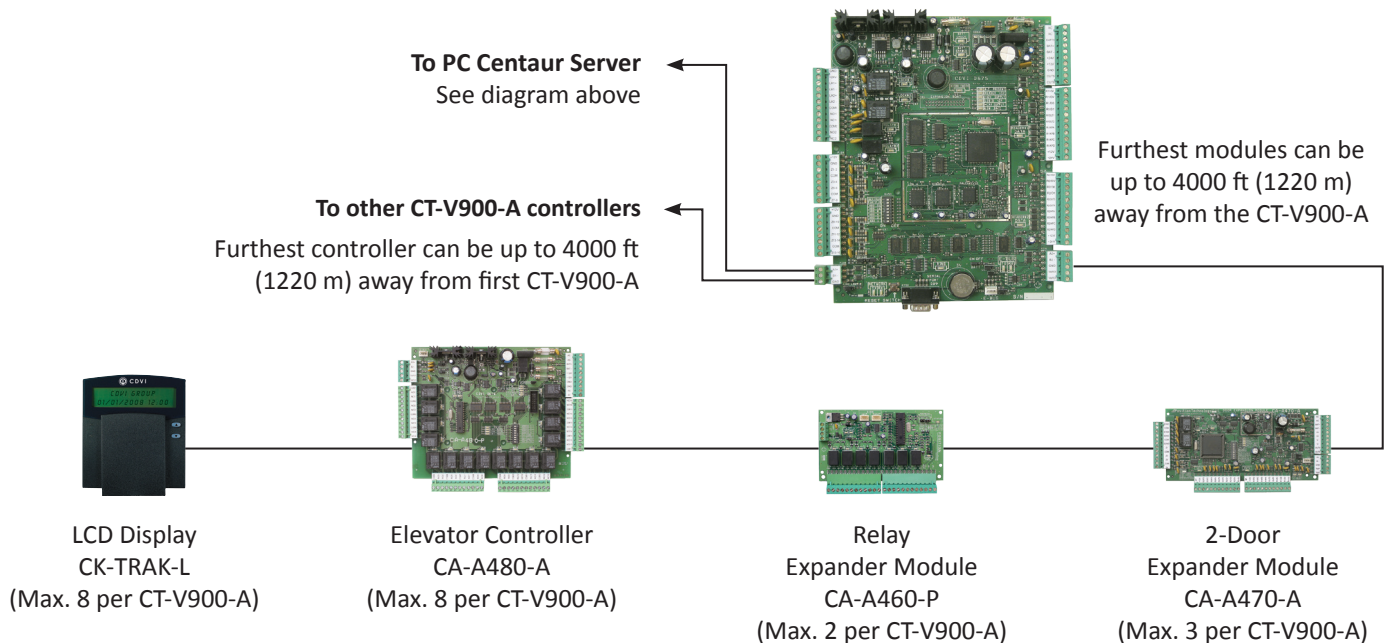

CENTAUR Kits



2DMK

2-Door Master Kit (Serial communication)

- 1 x CT-V900-A with pre-assembled universal plug-in power supply
- 2 x DGLP FN WLC26 proximity readers
- 1 x CENTAUR Lite Edition software (16 Doors)
- 1 x DB9FF10 Female-Female DB9 10 meter cable
- 1 x CDVI150 Transformer
(Supplies 1 x CT-V900-A and 3 x CA-A470-A)



2DMKUSB

2-Door Master Kit (USB communication)

- 1 x CT-V900-A with metal enclosure
- 2 x DGLP FN WLC26 proximity readers
- 1 x CENTAUR Lite Edition software (16 Doors)
- 1 x CA-A360-USB CAB USB/RS-485 Converter
- 1 x CDVI150 Transformer
(Supplies 1 x CT-V900-A and 3 x CA-A470-A)



2DMKIP

2-Door Master Kit (IP communication)

- 1 x CT-V900-A with metal enclosure
- 2 x DGLP FN WLC26 proximity readers
- 1 x CENTAUR Lite Edition software (16 Doors)
- 1 x RSIP RS232 to IP Converter
- 1 x CDVI150 Transformer
(Supplies 1 x CT-V900-A and 3 x CA-A470-A)

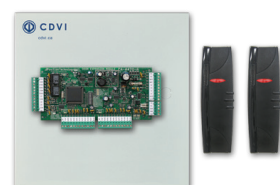

2DEKIT

2-Door Expander Kit

- 1 x CA-A470-A with metal enclosure
- 2 x DGLP FN WLC26 proximity readers

K1

KRYPTO High Security Card Reader



KRYPTO HIGH SECURITY SOLUTION



- Compatible with ATRIUM A22K controller
- FULLY secure RS-485 connection
- Reads 13.56 MHz Mifare Classic and DESFire EV1/EV2
- OSDP-2 compatible
- NFC compatible (mobile credential ready)
- Up to 2" (5 cm) read range
- Power requirements: 12 VDC

STAR1M

2 in 1 Mifare® Proximity Card Reader



- 1-Door Stand-Alone or Wiegand 26, 30 or 44 bit output
- Mifare® 13,56 MHz technology
- 300 card Stand-Alone capacity
- 4" (10 cm) read range
- 10 ft (3 m) of cable (AWG28)
- PCB sealed in epoxy
- Operating temp: -13°F to 158°F (-25°C to 70°C)
- Power requirements: 12 VDC

SOLARMB

Mifare® Proximity Card Reader



- Reads Mifare® Classic 13,56 MHz
- Desfire EV1 model : **SOLARMBD**
- Wiegand 26, 30 or 44 bit output
- Indoor/Outdoor (PCB sealed in epoxy)
- 4" (10 cm) read range
- Illuminated card reader (Blue, green and red).
- Operating temp: -13°F to 158°F (-25°C to 70°C)
- Power requirements: 12 VDC
- Consumption : 100 mA.

SOLSYSDW

Mifare® EV1 DESFire Card Readers



- Mifare® 13.56 MHz technology.
- Desfire EV1 (2K to 8 K) or Classic.
- AES 128 encryption
- 26, 30 or 44-bit Wiegand output
- PCB sealed in epoxy.
- Audible and visual feedback.
- Power requirements: 12 VDC
- Operating temp: --40°F to 158°F (40°C to 70°C)
- Consumption : 200 mA.

DGLP M WLC

Mifare® Proximity Reader



- Rugged polycarbonate
- 26, 30 or 44-bit Wiegand output
- PCB sealed in epoxy.
- Dust/Weather/Vandal resistant
- Audible and visual feedback.
- Power requirements: 12 VDC
- Operating temp.: -13°F to 158°F (-25°C to 70°C)

DGLI M WLC

Mifare® Proximity Reader



- Stainless steel proximity reader
- 26, 30 or 44-bit Wiegand output
- Mifare® 13.56 MHz technology.
- PCB sealed in epoxy.
- Dust/Weather/Vandal resistant
- Audible and visual feedback.
- Power requirements: 12 VDC
- Operating temp: -13°F to 158°F (-25°C to 70°C)

DGLP WLC26 / DGLP FN WLC26

Multi-Technology Wiegand Proximity Reader

DGLP FN WLC26



- Rugged polycarbonate
- 26-bit format Wiegand output
- Compatible with CDVI, Centaur (Position Technology) and most 26-bit format cards.
- Up to 3.5" (8 cm) read range
- Potted electronics
- Red/Green LEDs and Buzzer
- Power requirements: 12 VDC

DGLI WLC26 / DGLI F WLC26

Multi-Technology Wiegand Proximity Reader

DGLI F WLC26



- Stainless steel proximity reader
- Dust/Weather/Vandal resistant
- 26-bit format Wiegand output,
- Compatible with CDVI, Centaur (Position Technology) and most 26-bit format cards.
- Up to 3.5" (8 cm) read range
- Potted electronics
- Red/Green LEDs and Buzzer
- Power requirements: 12 VDC

NANOPB (Black) / NANOPW (White)

Mini Wiegand Proximity Reader



- Reads CDVI Wiegand 26-bit card encoding
- 4" (10 cm) read range
- Illuminated card reader (Blue, green and red).
- Audible feedback
- PCB sealed in epoxy
- Operating temp: -13°F to 158°F (-25°C to 70°C)
- Power requirements: 12 VDC

STARPB (Black) / STARPW (White)

Mullion Proximity Reader



- Reads CDVI and most popular 26-bit Wiegand card encoding
- 4" (10 cm) read range
- Illuminated card reader (Blue, green and red).
- Audible feedback
- PCB sealed in epoxy
- Operating temp: -13°F to 158°F (-25°C to 70°C)
- Power requirements: 12 VDC

SOLARPB (Black) / SOLARPW (White)

Multi-Technology Proximity Reader



- Reads CDVI and most popular 26-bit Wiegand card encoding
- 4" (10 cm) read range
- Illuminated card reader (Blue, green and red).
- Audible feedback
- PCB sealed in epoxy
- Operating temp: -13°F to 158°F (-25°C to 70°C)
- Power requirements: 12 VDC

SOLARKPB / SOLARKPW

Keypad & Multi-Technology Reader



SOLARKPB

SOLARKPW

- Touch sensitive keypad
- Keypad code of 4 to 8 digits
- Reads CDVI and most popular 26-bit Wiegand card encoding
- 4" (10 cm) read range
- Audible feedback
- PCB sealed in epoxy
- Operating temp: -13°F to 158°F (-25°C to 70°C)
- Power requirements: 12 VDC

DGLP60WLC26

Wiegand Long Range Reader



- 23.5" (60 cm) read range
- Selectable 26, 30 or 44-bit Wiegand output
- Compatible with CDVI, Centaur (Position Technology) and most 26-bit format cards.
- Red/Green LEDs and Buzzer
- Operating temp.: -40°C to 70°C
- Power requirements: 12 VDC

GALEO/W

Keypad with Backlit Keys



- 26-bit Wiegand keypad
- Heavy-duty ZAMAK cast alloy (Zinc, Aluminium, Magnesium and Copper)
- Eye-catching bright blue back-lighting
- Potted electronics
- Integrated Piezo/Buzzer
- Power requirements: 12 VDC

KCPROXWLC26

Proximity card reader and keypad



- Vandal proof housing
- Backlit keys
- Compatible with CDVI, Centaur (Position Technology) and most 26-bit format cards.
- Red/Green LEDs and Buzzer
- Operating Temp: -13°F to 140° (-25°C to 60°C)

R125USB

Card Enrollment Unit

Cards are automatically enrolled in the ATRIUM or CENTAUR database. Simply present the CDVI card or badge encoding in front of the unit and the code is read by the PC and put into the cardholder's file.



- Connect to PC USB port
- Cable included
- 3.4" x .9" x .43" (87 x 23 x 11 mm)
- Also available to read; HID cards: **R125USBH** MIFARE cards: **R1356USB**

TAG-EV2

Mifare DESFire EV2 Tag



DESFire EV2 is the most recent technology with a better read range and faster card reading than EV1.



- DESFire EV2 4k format
- 13.56 MHz proximity card
- 1.75" (L) x .5" (H) x .08" (D)
(45 x 13 x 2 mm)
- Comes in packs of 25
- Other encoding available:
CDVI 125 kHz: **TAG**
HID 125 kHz: **TAG-H**

KTAG25

Black Key Tag



- CDVI 26-bit Wiegand format
- 125 kHz proximity card
- Polycarbonate tag
- 1.6" (L) x 1.3" (H) x .16" (D)
(40 x 33 x 4 mm)
- **Sequentially generated decimal card numbers (printed on each card)**
- Comes in packs of 25
- Other encoding available:
HID 125 kHz: **KTAGH25**
Mifare Classic 1k: **KTAGM25**

CS25

Standard clamshell card



- CDVI 26-bit Wiegand format
- 125 kHz proximity card
- 3.35" (L) x 2.1" (H) x .08" (D)
(85 x 54 x 1.8 mm)
- **Sequentially generated decimal card numbers (printed on each card)**
- Comes in packs of 25
- Other encoding available:
HID 125 kHz: **CSH25**
Mifare Classic 1k: **CSM25**

BTAG25

Blue Key Tag



- CDVI 26-bit Wiegand format
- 125 kHz proximity card
- Polycarbonate tag
- 1.6" (L) x 1.3" (H) x .16" (D)
(40 x 33 x 4 mm)
- **Sequentially generated decimal card numbers (printed on each card)**
- Comes in packs of 25
- Other encoding available:
HID 125 kHz: **BTAGH25**
Mifare Classic 1k: **BTAGM25**

ISO25

Printable ISO Card



- CDVI 26-bit Wiegand format
- 125 kHz proximity card
- Printable on both sides
- 3.35" (L) x 2.1" (H) x .08" (D)
(85 x 54 x 1.8 mm)
- **Sequentially generated decimal card numbers (printed on each card)**
- Comes in packs of 25
- Other encoding available:
HID 125 kHz: **ISOH25**
Mifare Classic 1k: **ISOM25**

HEXADECIMAL CREDENTIALS

Randomly generated hexadecimal card numbers



All these are 125 kHz CDVI encoding card:

- CP:** Thin card for printing photos and text (ISO)
- CPE:** Standard clamshell card
- PPC:** Rugged gray polycarbonate key ring card
- BP:** Elegant leather key ring tag
- PP:** Stylish black polycarbonate tear drop card, available for Mifare® proximity reader: PVP

DISCTAG25

Mini PVC Tag



- CDVI 26-bit Wiegand format
- 125 kHz proximity card
- Adhesive on one side
- .8" dia x .06" (D) (20 x 1.5 mm)
- **Sequentially generated decimal card numbers (printed on each card)**
- Comes in packs of 25
- Other encoding available:
HID 125 kHz: **DISCTAGH25**
Mifare Classic 1k: **DISCTAGM25**

GALEOBT

Bluetooth Stand-Alone Keypad with Backlit Keys



Turn your Smartphone into a Keypad

Bluetooth™
4.0
Low Energy



- Indoor/outdoor keypad
- 100 user codes (4 or 5 digits)
- Remote controller

The GALEOBT includes a 10 ft (3 m) cable to connect to the remote controller. 30 ft (10 m) maximum distance between the keypad and the remote controller

- 3 independent relay outputs
- Request-to-exit input
- Programmable audible feedback buttons
- Power: 12/48 VDC or 12/24 VAC
- Timed (1 to 99 sec.) or latched output

GALEO Keypad

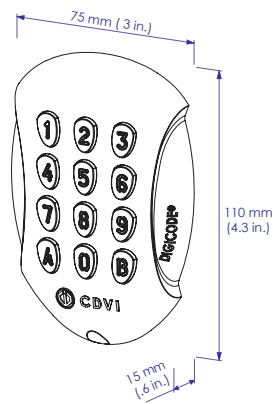

- CE
- RoHS
- IP64
- IK10
- Pulvérisation de sel
- Test de vibrations
- 25°C à +70°C

Remote controller

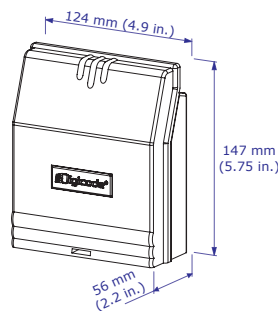

- CE
- RoHS
- IP52
- 25°C à +70°C

PROMI ECO

1-Door Stand-Alone Keypad



- Built-in controller
- 100 user codes (3 to 8 digits)
- Request-to-exit input
- Easy setup
- Audible and visual feedback
- Power requirements: 12 VDC/AC

KCIEN/SBP

Stand-Alone Keypad with Backlit Keys



- Illuminated stainless steel keypad
- 100 user codes (4, 5 or 6 digits)
- 2 form C outputs (8 A/250 V), timed (1 to 99 sec.) or latched
- Audible feedback buttons
- Request-to-exit input
- Potted electronics
- Power requirements: 12/24 VAC or 12/48 VDC
- Available with call button (Doorbell/ Chime): KCIEN



BKC-5000B

3 in 1 Device - Mobile, Keypad and Card Reader



- Compatible with iOS and Android
- Proximity distance 164 ft in open space without blocking by metal or concrete wall/door frames
- 200 users with mobile app
- 1000 event log
- Easy plug & play installation



2400KIT

Universal Door Strike

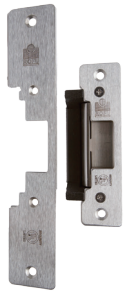

- Designed for cylindrical locksets
- Fail safe or fail secure (default)
- Includes 2 faceplates
- Low profile : 1 1/4" depth overall
- Static strength : 1000 lbs (454 kg)
- Latch throw : 1" max with 1/8" door gap
- Current draw : 300 mA/12 VDC; 150 mA/24 VDC
- Dimensions : 4 7/8" x 1 1/4" x 1 1/4"

2435KIT

Heavy Duty Door Strike



- Designed for cylindrical or mortise locksets
- Fail safe or fail secure (default)
- Includes 5 faceplates
- Heavy duty stainless steel construction
- Static strength : 1000 lbs (454 kg)
- Latch throw : 1" max with 1/8" door gap
- Current draw : 250 mA/12 VDC; 150 mA/24 VDC
- Dimensions : 3 5/16" x 1 5/8" x 1 13/16"

2490

Fully Surface Mount Door Strike (1/2")



- Fully Surface Mount
- 1/2" Latch throw
- Designed for push bar
- Fail safe or fail secure (default)
- UL Listed
- Static Strength : 1500 lbs (680 kg)
- Current Draw: 540 mA/12 VDC; 270 mA/24 VDC
- Dimensions : 8" x 1 3/4" x 1/2"

2470

Fully Surface Mount Door Strike (3/4")



- Fully Surface Mount
- 3/4" Latch throw
- Designed for push bar
- Fail safe or fail secure (default)
- UL Listed
- Statc Strength : 1500 lbs (680 kg)
- Current Draw: 540 mA/12 VDC; 270 mA/24 VDC
- Dimensions : 8" x 1 3/4" x 3/4"

2460

Partial Surface Mount Door Strike



- Partial surface mount
- Designed for crash bars
- Latch & lock monitoring
- Fail safe or fail secure (default)
- Static strength : 1500 lbs (680 kg)
- Zinc alloy construction in black finish
- Accommodates 11/16" (17 mm) latchbolt
- Current draw: 230 mA/12 VDC; 140 mA/28 VDC
- Dimensions : 9 1/8" x 1 9/16" x 13/16"

3820

Motorized Cabinet Lock



- Surface & side mount
- Designed for cabinets and lockers
- Fail secure
- Stainless steel locking pin assembly
- Field adjustable relock time delay
- Lock or door status monitoring
- Current draw in standby: 69 mA @ 12 VDC; 69 mA @ 24 VDC
- Dimensions : 2 3/8" (L) x 2 3/8" (W) x 7/8" (H) 2 3/8" (L) x 13/16" (W) x 1/4" (H)

SM300

300kg (660lbs) Holding Force



- Surface mount installation
- Power requirements: 12/24 VDC
- Current Draw: 500 mA @ 12 VDC, 250 mA @ 24 VDC
- Monitoring sensor
- Visual feedback (red & green)
- Dimensions: 10" x 1.7" x 1" (250 x 42.5 x 26 mm)

P400RN

400kg (880lbs) Holding Force



- Retrofit electromagnetic door handle
- Complete Aluminium housing
- Power requirements: 12/24 VDC
- Current Draw: 560 mA @ 12 VDC, 270 mA @ 24 VDC
- 15,75" (H) x 5" (W) x 2,7" (D) (40 x 12,6 x 6,8 cm)

SM500

500kg (1100lbs) Holding Force



- Surface mount installation
- Power requirements: 12/24 VDC
- Current Draw: 500 mA @ 12 VDC, 250 mA @ 24 VDC
- Monitoring sensor
- Visual feedback (red & green)
- Dimensions: 10.5" x 2.9" x 1.6" (265 x 73 x 40 mm)

PWM25PSR

800kg (1750lbs) Holding Force



- Shearlock door handle
- Patented self-aligning mechanism
- Input voltage: 12, 24 or 48VDC
- Current Draw: 460 mA @ 12 VDC, 230 mA @ 24 VDC, 150 mA @ 48 VDC
- Available in black: PWM25PSR/RAL NOIR

ESM500

500kg (1100lbs) Holding Force

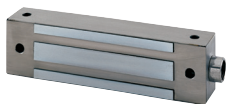

- Exterior applications & High-traffic areas
- Power requirements: 12/24 VDC
- Current Draw: 500 mA @ 12 VDC, 250 mA @ 24 VDC
- Monitoring sensor
- Visual feedback (red & green)
- Dimensions: 11.35" X 2.5" X 1.5" (288.5 x 64 x 37.5 mm)

PWM25ER

800kg (1750lbs) Holding Force



- Shearlock flush mount installation
- Patented self-aligning mechanism
- Input voltage: 12, 24 or 48 VDC
- Current Draw: 460 mA @ 12 VDC, 230 mA @ 24 VDC, 150 mA @ 48 VDC
- Surface option: PWM25SR

CZ3000

1500kg (3300lbs) Holding Force



- Shearlock
- Self-Aligning
- Power requirements: 12/24 VDC
- Current Draw: 600 mA @ 12 VDC and 300 mA @ 24 VDC
- Compact mortise-mount
- 8" H) x 1.2" (W) x 1.25" (D) (206 x 30 x 32 mm)
- Optional surface mount kit (KCZ 3000)

V5EI

500kg (1100lbs) Holding Force



- Flush mount installation
- Sliding door applications
- Power requirements: 12/24 VDC
- Current Draw: 550 mA @ 12 VDC, 270 mA @ 24 VDC
- 10.5" (H) x 2.5" (W) x 1.5" (D) (266 x 66 x 40 mm)
- Stainless steel

CDVI's high quality RADIUM transmitters/receivers are the perfect solution to operating parking gates, garage doors, wheelchair-accessible doors, etc. The RADIUM wireless systems offer longer range up to 820 ft (250 m), less interference jamming and excellent reliability. KeeLoq® Rolling Code technology ensures ultra-secure transactions.

R1

1-Button Remote



- European design
- Range up to 820 ft (250 m)
- Ergonomic, rugged & durable
- One CR2032 lithium battery
- Also available with built-in proximity tag

WRW

Wiegand Wireless Receiver

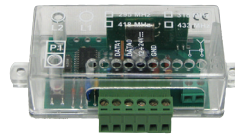

- 26-bit Wiegand output
- Power: 12 or 24 V (AC or DC)
- Dimensions: 4.3" x 1.75" x 1.1" (105 x 45 x 28 mm)
- Compatible with ATRIUM, CENTAUR or any 26-bit Wiegand-capable systems

R2 / R2T

2-Button Remote



R2

R2T

- European design
- Range up to 820 ft (250 m)
- Ergonomic, rugged & durable
- One CR2032 lithium battery (R2) or Two CR2016 lithium battery (R2T)
- R2T was designed for use in harsh environments
- Also available with built-in proximity tag

WR2LCD

2-Relay Stand-Alone Receiver with LCD Display



- Easier to program
- Up to 100 transmitter keys
- 1 NO relay + 1 NO/NC relay (24 VA)
- Self-learning memorization
- Pulse, latched or delayed relay output
- Power: 12 or 24 V (AC or DC)
- Dimensions: 4.3" x 1.75" x 1.1" (105 x 45 x 28 mm)

R4

4-Button Remote



- European design
- Range up to 820 ft (250 m)
- Ergonomic, rugged & durable
- One CR2032 lithium battery
- Also available with built-in proximity tag

WRAP

ATRIUM Plug-in Wiegand Wireless Receiver

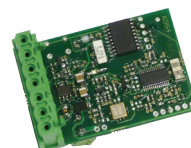

- Connect directly to ATRIUM Wiegand port
- Dimensions: 2.2" x 1.42" (55 x 36 mm)

WR4

4-Relay Stand-Alone Receiver



- Up to 85 transmitter keys
- 2 NO relay + 2 NO/NC relay
- Standard pulse output
- Relay 4 supports latched output
- Voltage: 12 or 24 V (AC or DC)

SEA433

433MHz Tuned Antenna



- Increase reception and/or range
- 11.5 ft (3.5 m) coaxial cable (RG 58) included
- “L”-shaped bracket for wall-mounting

WRACT

Wiegand Active Tag Receiver



- Output: 26 bit Wiegand
- Compatible with RACT active tag remote
- Sensitivity adjustable up to 65 ft (20 m)
- Enclosure protection: IP 65
- Input voltage: 12 VAC or DC

RACT

Active Tag Remote



- Transmits continually
- Tri-color LED for battery status
- Range (line of sight): 20 m (65 ft)
- Two CR2016 lithium battery
- Operating temperature: -22°F to 158 °F (-30°C to +70 °C)
- Dimensions: 2.4” x 1.4” x .63” (61 x 36 x 16 mm)
- Available with HID passive tag : **RACTH**

WRAES

Wireless Receiver with AES128 Encryption



- 2 in 1, Stand-alone or Wiegand 26, 30 or 44-bit output
- AES128 encrypted signal
- 500 transmitters capacity
- 2 Relays onboard
- Compatible with R2TAES, R2AES & R4AES remotes

AES128
ENCRYPTION

R2TAES

2-Button Mini Remote with AES128 Encryption



- AES128 encrypted signal
- Heavy-duty construction
- Range up to 820 ft (250 m)
- Ergonomic, rugged & durable
- Two CR2016 lithium battery
- Also available with a built-in DESFire EV2 tag (KRYPTO ready) : **R2EV2**

AES128
ENCRYPTION

R2AES

2-Button Remote with AES128 Encryption



- AES128 encrypted signal
- European design
- Range up to 820 ft (250 m)
- Ergonomic, rugged & durable
- One CR2032 lithium battery
- Also available with a built-in DESFire EV2 tag (KRYPTO ready) : **R2EV2**

AES128
ENCRYPTION

R4AES

4-Button Remote with AES128 Encryption



- AES128 encrypted signal
- European design
- Range up to 820 ft (250 m)
- Ergonomic, rugged & durable
- One CR2032 lithium battery
- Also available with a built-in DESFire EV2 tag (KRYPTO ready) : **R4EV2**

AES128
ENCRYPTION



U4GO

High Performance UHF integrated system

U4GO is a high performance UHF (902-928 MHz) integrated system perfect for vehicle and people identification. The **U4GO** provides secure long-range access for many applications such as parking facilities, gated communities, campus' and rolling stock. The **U4GO** is easy to install, versatile, and are perfectly suited for access control systems (Wiegand output). The high security protocol (AES128) RF module can also manage up to 100 remote transmitters.

A6U49

Mid-Range UHF Reader (6 meters)



- Compatible with ATRIUM, CENTAUR or any access control system with a Wiegand input port
- Read range: 20 ft (6 m)
- Vehicle moving speed : 50 mph (80 Km/h)
- Operating frequency : 902-928 MHz
- Protocols: ISO18000-6B, ISO18000-6C /EPC GEN2
- Supplied power supply
- Dimensions: 9.25" x 9.25" x 2.25" (235 x 235 x 57 mm)

A10U49

Long-Range UHF Reader (10 meters)



- Compatible with ATRIUM, CENTAUR or any access control system with a Wiegand input port
- Read range: 33 ft (10 m)
- Vehicle moving speed : 50 mph (80 Km/h)
- Operating frequency : 902-928 MHz
- Protocols: ISO18000-6B, ISO18000-6C /EPC GEN2
- Supplied power supply
- Dimensions: 17.5" x 17.5" x 2.2" (445 x 445 x 55 mm)

ATU48

UHF Adhesive Windshield RFID Tag



- Passive, battery free tag
- Thin and flexible sticker format
- Sold in packs of 10
- Customized printing available on request
- Compatible with A6U49 and A10U49

CTU48

UHF ISO RFID Card



- Customized printing available on request
- Sold in packs of 10
- Also available in dual technology (UHF + Mifare DESFire EV2 or other combo)
- Compatible with A6U49 and A10U49

PTU48

UHF License Plate RFID Tag



- Designed for vehicle identification
- Dust and water resistance
- Operates in harsh environment
- Compatible with A6U49 and A10U49

CHU48

UHF RFID Card Holder



- Card holder for UHF CTU48
- Back with suction cup for easy fasten on a car window
- PVC material
- Size: 3.15" x 2.3" x .6" (90 x 58 x 15 mm)

BIOSYS

Stand-Alone or Networked Fingerprint Reader



- Stores up to 500 fingerprints
- 26, 30 or 44-bit Wiegand output
- MIFARE® reader
- 2 operating modes:
 - Fingerprint only
 - Fingerprint + Card
- Remote controller with 6 wire cables between remote controller and the fingerprint reader (RS485 communication between remote controller and fingerprint reader)
- On-board Ethernet port (10/100 base T)
- 2 relay outputs (Lock & Alarm)
- REX and door contact input
- Accelerometer Tamper Switch
- 1 x master card and 10 x MIFARE® card included
- Power requirements: 12 VDC
- Mounted in solid aluminium housing
- Operating temperature: 32°F to +122°F (0°C to 50°C)
- Dimensions (H x L x D):
 - Fingerprint reader = 6.5" x 3.25" x 1" (163 x 82 x 26 mm)
 - Remote electronic = 5.55" x 4.9" x 2.2" (147 x 124 x 55 mm)

PREX

Request-to-Exit Illuminated Press Button



- 1 x NO & NC contact outputs
- Momentary switch
- Includes two plates, single gang and mullion size
- Input voltage : 12 VDC @ 5 A, 24 VDC @ 5 A, 110 VAC @ 5 A or 220 VAC @ 3 A
- UL, CE, IP65 & ROHS certified
- LED rating: 15 mA @ 12 VDC
- Also available with a latch switch: **PREX-L**

FLEX30

Stainless Steel Door Loop



- 12" (30 cm) door loop
- Armored stainless steel loop with flush mount heads for wire termination inside door and frame
- Cast aluminium end caps

VHESS

Surface Mount Infrared Request to Exit Switch



- Stainless steel
- Range: 10 to 20" (25 to 50 cm)
- Visual and audible feedback
- Input voltage: 9 or 15 VDC.
- Consumption:
 - Standby = 25 mA.
 - Activation = 65 mA.

PBM

Illuminated Momentary Push Button



- NO and NC contact outputs
- Momentary switch
- Blue LED rating: 15 mA @ 12 VDC
- Switch rating : 12 VDC @ 5 A, 24 VDC @ 5 A, 110 VAC @ 5 A or 220 VAC @ 3 A
- IP65, UL, CE & ROHS certified
- Also available with a latch switch: **PBL**

KRYPTO

HIGH SECURITY SOLUTION

Instant High Security Out of the Box



Scan to add CDVI's
contact details to
your smartphone



828, Saint-Martin Blvd West, Laval, Quebec, Canada, H7M 0A7
Toll Free: 1-866-610-0102 • Tel.: (450) 490-7945 • Email: info@cdvi.ca

www.cdvi.ca

All the information contained within this document (pictures, drawing, features, specifications and dimensions) could be perceptibly different and can be changed without prior notice.
Reference manual: CDVI_CATALOGUE_PC_01_EN_LETTER_CMYK.pdf - Printed in Canada - January 2020